

TECHNICAL DATA SHEET

VALSIR® WASTE SYSTEMS

AIR ADMITTANCE VALVE



valsir®
QUALITY FOR PLUMBING



Charateristics

Code: VS0700401

Pipes diameters compatibility: 32-40-50-63 mm

Air flow rate: 6.1 l/s

CE Mark: EN12380

Height: 79.5 mm

Diameter: 70 mm

Working temperature: -20°C / +60°C



DESCRIPTION:

Air admittance valve with membrane that allows to balance the depressions (NEGATIVE PRESSURE) which are created inside of waste system due to the passage of fluids within both the horizontal branches and the vertical stack. Complies with EN12380 standard and thanks to the classification in Class A it can be installed below the level of the flow. Moreover, thanks to the classification Class I it allows installation with operating temperatures ranging from -20 ° C to + 60 ° C.



WASTESYSTEMS

63

Technical specs:

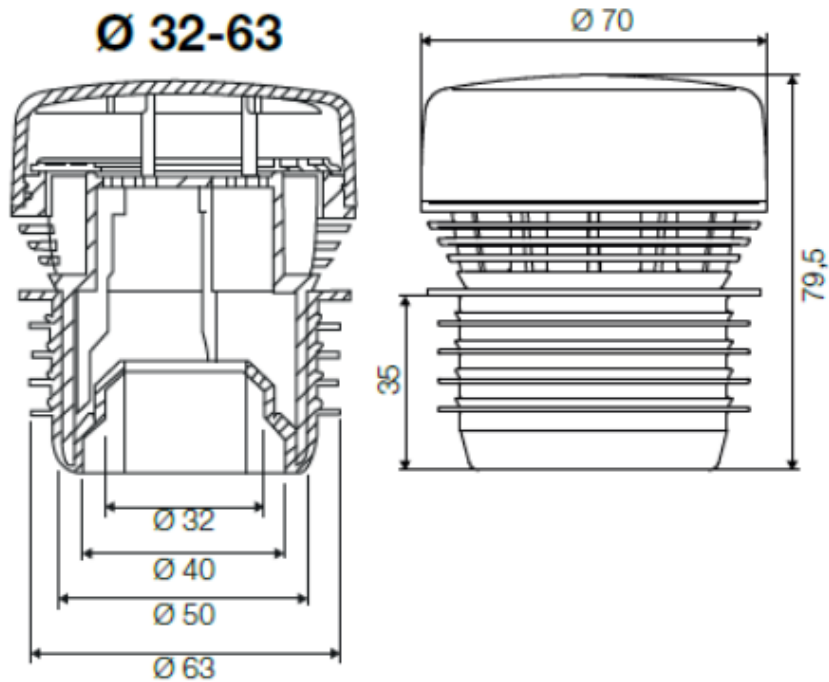

Pipes diameters compatibility:





WASTESYSTEMS

110

Charateristics

Code:	VS0700402
Pipes diameters compatibility:	70-75-90-100-110 mm
Air flow rate:	23.2 l/s
CE Mark:	EN12380
Height:	108 mm
Diameter:	125 mm
Working temperature:	da -20°C a- +60°C



DESCRIPTION:

Air admittance valve with membrane that allows to balance the depressions (NEGATIVE PRESSURE) which are created inside of waste system due to the passage of fluids within both the horizontal branches and the vertical stack. Complies with EN12380 standard and thanks to the classification in Class A it can be installed below the level of the flow. Moreover, thanks to the classification Class I it allows installation with operating temperatures ranging from -20 ° C to + 60 ° C.



WASTESYSTEMS

110

Technical specs:

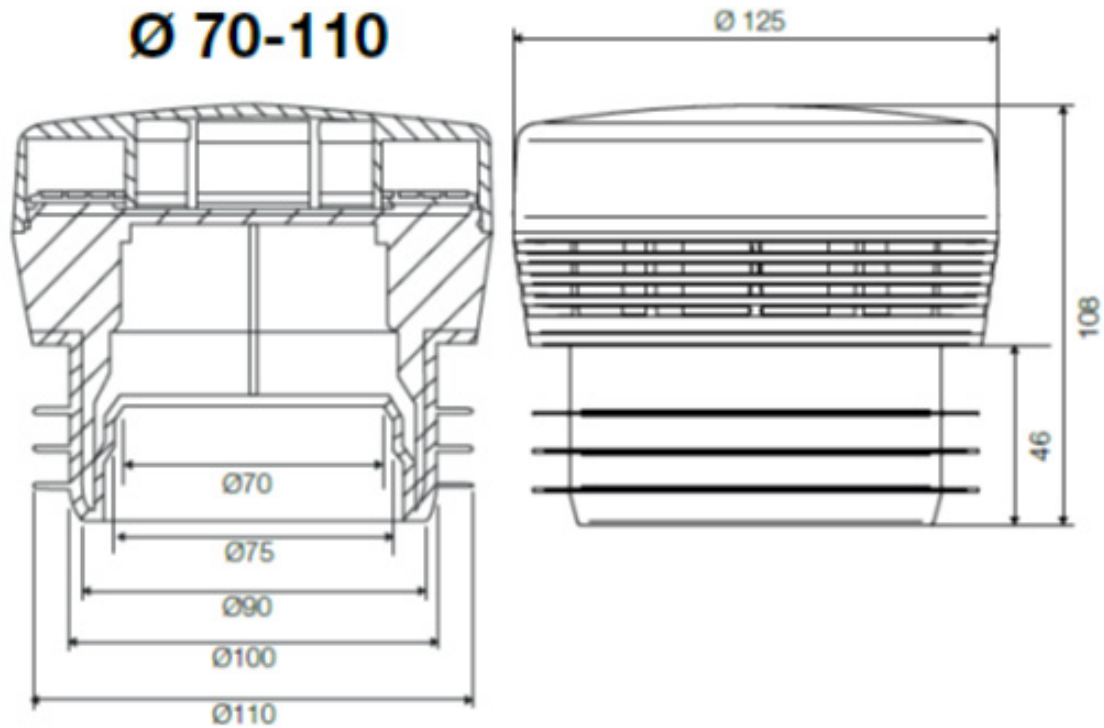

Pipes diameters compatibility:



PLUMBING

WASTE SYSTEMS



SUPPLY SYSTEMS



GAS SYSTEMS



FLUSH SYSTEMS



BATHROOM SYSTEMS



TRAPS



RADIANT SYSTEMS



DRAINAGE SYSTEMS



HRV SYSTEM



ACADEMY



SEWER SYSTEMS



WATER TREATMENT



BUILDING

valsir[®]
QUALITY FOR PLUMBING

VALSIR S.p.A.
Località Merlaro, 2
25078 Vestone (BS) - Italy
Tel. +39 0365 877.011
Fax +39 0365 81.268
e-mail: valsir@valsir.it

www.valsir.com

Soggetta all'attività di direzione e coordinamento ex art. 2497 bis C.C. da parte di Silmar Group S.p.A. - Codice Fiscale 02075160172

TO2-20271 - Novembre 2017